

## EFFECT OF FIELD STRENGTH IN THE VELOCITY ANISOTROPY OF FERROFLUIDS

B. Samuel Ebinezer<sup>1</sup> and L. Palaniappan<sup>2\*</sup>

<sup>1</sup>Department of Physics, Annamalai University – 608002, TN, India

<sup>2</sup>School of Physics, Universiti Sains Malaysia, 11800 USM Pulau Pinang, Malaysia

\*Corresponding author: lp\_dde\_au@yahoo.com

**Abstract:** *Ultrasonic velocity measurements were made on the starch coated magnetite particles in aqueous carrier under various external magnetic field strength. Density values are presented under no field condition and a few acoustical parameters were calculated. All the observations are interpreted in terms of grain-grain interaction and grain-field interaction that exist in the system. The field strength is found to enhance the structural formation in the system irrespective of its direction.*

**Keywords:** Ultrasonic velocity, ferrofluid, magnetic field, grain-grain interaction, grain-field interaction

### 1. INTRODUCTION

Ferrofluids which consist of 10 to 100 Å size particles suspended in various carrier fluids have been considered to have much more in common with liquid crystals and ordinary liquid mixtures than with various solid ferromagnetic materials. The behavior of ultrasonic wave propagation through magnetic fluids, in the presence of magnetic fields is a relatively unexplored area. The significance of these fluids need not be emphasized as these are part of the expanding nano science and technology.

Although ferrofluids consist of ferromagnetic particles suspended in a fluid, the magnetic behavior is generally described by paramagnetic theories and the ultrasonic behavior of the fluids is approached from the view point of hydrodynamics. Many authors<sup>1-3</sup> have followed such type of approaches for their interpretation even in studying the ultrasonic attenuation and velocity measurements. Further, they have concluded that pulse-echo experiments were more suitable for attenuation measurements than for measuring changes in velocity, due to a magnetic field, for which continuous wave (CW) interferometer is found to be the best.

Many workers<sup>4-8</sup> have used only CW method for the measurement of ultrasonic velocity in ferrofluids. Chung<sup>9</sup> concluded that the CW method proved

to be well-suited for studying the velocity changes due to a magnetic field. On this basis, the present study is aimed at measuring the ultrasonic wave velocity in ferrofluids for different field strengths based on CW method.

## 2. EXPERIMENTAL DETAILS

Ferrofluids synthesized in the pilot laboratory at Annamalai University and tested at the Ferrofluids Laboratory at Pondicherry have been used for the analysis. The fluid was kept for more than one month after its preparation and was found to be highly stable. Further, the weight fraction of the fluid was obtained and is found to be in the satisfactory level. Hence, the synthesized fluid was used for further observations.

All the chemicals required for sample preparation were purchased from S.D. Fine Chemicals and Aldrich Chemicals. Out of six samples synthesized in a similar procedure, the one which gave the maximum magnetization properties was used for further experimentation.

The particle used was magnetite, the surfactant was starch and the carrier was water. The basic properties such as the saturation field, shear viscosity, initial susceptibility, density and particle volume concentrations at 303 K are found at the Ferrofluid Laboratory, Pondicherry and these values were given as 28 mT, 4.8 cP, 0.53, 1172.5 kgm<sup>-3</sup> and 3.8%, respectively. The average diameter of the magnetic grains as obtained from VSM measurements was 23 nm.

The ultrasonic sound velocity in the fluids was measured by using the CW ultrasonic interferometer working at 2 MHz frequency (Fig. 1). It has an overall accuracy of  $\pm 0.1\text{ms}^{-1}$ . The sound velocity in the fluid under no external and various external fields up to 0.5 T in parallel and perpendicular orientations were measured by accordingly placing the cell (Fig. 2) in between the pole pieces of a strong electromagnet. Each measurement was made 35 min after the application of magnetic field as the system needs some time to set at equilibrium.<sup>10</sup> It is to make the particles of the fluid to set at equilibrium.

The maximum field generated by the electromagnet 0.5 T and the field intensity between the pole pieces can be measured by Digital Gauss meter (Hybrid, New Delhi) with an accuracy of  $\pm 0.01$  mT.

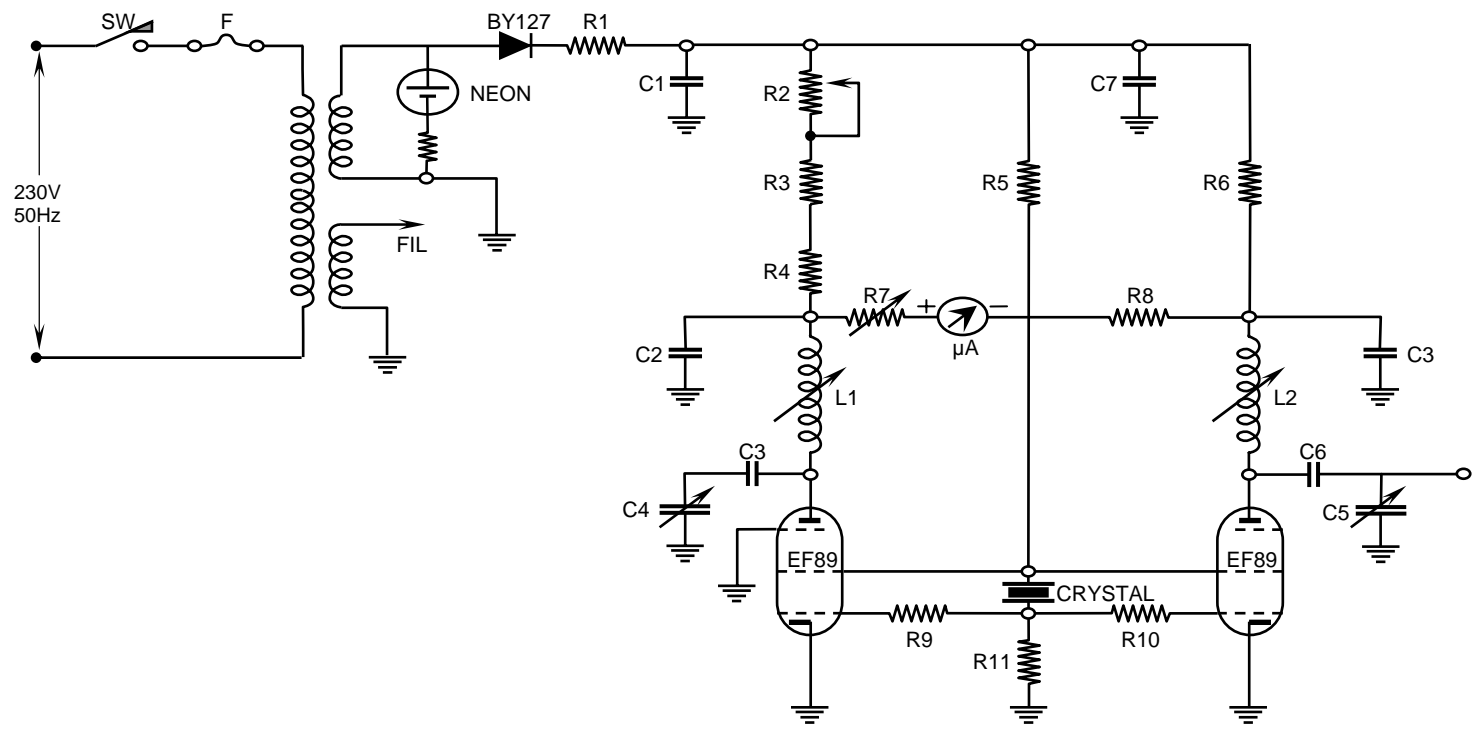

Figure 1: Circuit diagram of ultrasonic interferometer.

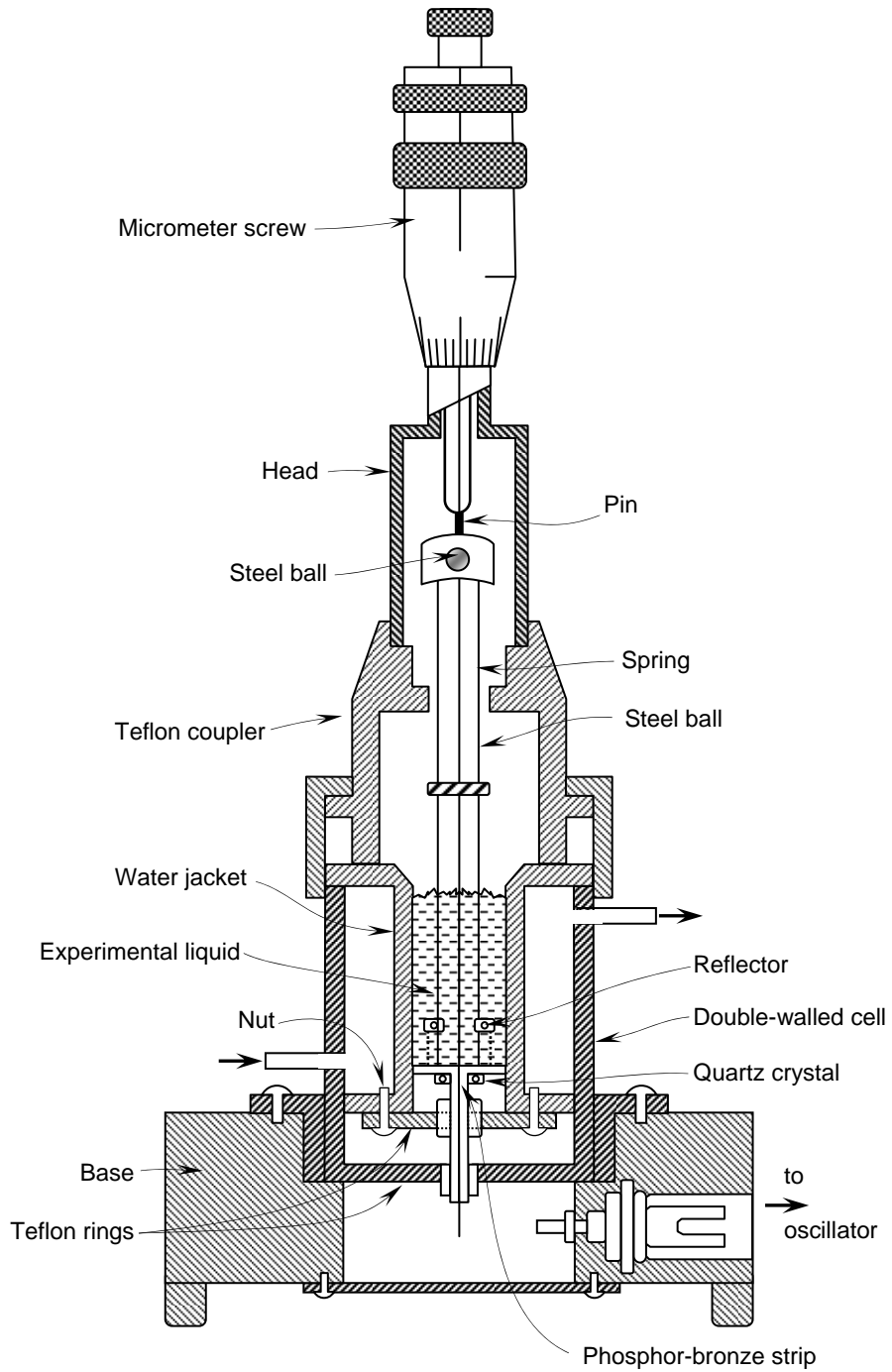

Figure 2: Micrometer cell assembly.

Based on Massart's method,<sup>11</sup> aqueous mixture of ferric and ferrous salts, and NaOH as an alkali source were prepared as stock solutions. The synthesis of magnetite nano particles has been carried out via a controlled chemical coprecipitation approach, as described in detail by Kim et al.<sup>12</sup> During the synthesis, N<sub>2</sub> gas was flown in a closed system through the reaction medium to prevent critical oxidation of Fe<sup>2+</sup>.

Various amounts of starch were dissolved in 100 ml de-ionized water at 90°C. After the starch was thoroughly dissolved, the solution was placed immediately in a 60°C water bath until the starch solution temperature was decreased to the water bath temperature.

Precursor solutions for the Fe source were poured into the prepared starch solution under vigorous stirring. 25 ml of iron containing starch source solution was added drop-wise into 200 ml of 1.0 μl NaOH under vigorous mechanical stirring (2000 rpm) for two hours at 60°C.

During boiling, approximately 50% of the water was evaporated and the remaining solution was cooled to room temperature for 12 h. The remaining gels were washed out with de-ionized water until the pH was less than 8.5. The starch coated iron oxide particles were dialyzed at 37°C for 2–3 days with adequate stirring.

### 3. RESULTS AND DISCUSSION

Using the following standard relations, the adiabatic compressibility ( $\beta$ ), the free length ( $L_f$ ) and the acoustic impedance ( $Z$ ) were calculated.

$$\beta = \frac{1}{U^2 \rho} \quad (1)$$

$$L_f = K_T \beta^{1/2} \quad (2)$$

$$Z = \rho U \quad (3)$$

where  $K_T$  is the temperature dependent constant equal to  $199.53 \times 10^{-8}$  in M.K.S units at 303 K.

The values of density ( $\rho$ ) and sound velocity ( $U$ ) together with the calculated parameters for the best ferrofluid sample under parallel field conditions at 303 K are given in Table 1.

Table 1: Measured and calculated parameters for the best sample kept under parallel field at 303 K.

Field T	$\rho$ kg m <sup>-3</sup>	U ms <sup>-1</sup>	$\beta \times 10^{10}$ Pa <sup>-1</sup>	$L_f \times 10^{11}$ m	$Z \times 10^{-6}$ kg m <sup>-2</sup> s <sup>-1</sup>
0.00	1160.2	1452.2	4.0871	4.0338	1.6848
0.05	1160.2	1452.3	4.0865	4.0335	1.6849
0.10	1160.2	1452.5	4.0854	4.0329	1.6852
0.15	1160.2	1452.7	4.0843	4.0324	1.6854
0.20	1160.2	1453.1	4.0820	4.0313	1.6859
0.25	1160.2	1454.0	4.0769	4.0288	1.6869
0.30	1160.2	1454.5	4.0742	4.0274	1.6875
0.35	1160.2	1456.2	4.0647	4.0227	1.6895
0.40	1160.2	1457.3	4.0585	4.0197	1.6908
0.45	1160.2	1458.6	4.0513	4.0161	1.6923
0.50	1160.2	1459.5	4.0463	4.0136	1.6933

On comparing these values with the values obtained under no field condition, it is observed that the increasing strength of external magnetic field, in general shows a non-linear increase in sound velocity. This increment suggests the existence of interactions as in the system taken by Palaniappan and Karthikeyan.<sup>13</sup> The increase in velocity with field is found to be large at larger fields. This increasing trend was observed to produce a velocity variation of 7.3 ms<sup>-1</sup> for a maximum field of 0.5 T. However, the density remains the same as the observed value is bulk rather than layer density. The effect of magnetic field on the ferrofluid is expected to align the magnetic particles, which is only change in the layer and not in bulk, so that the bulk density remains the same.

The non-linear variation in the sound velocity (Fig. 3) indicates that there is an appreciable degree of interactions in the medium<sup>14-16</sup> for which the only possibility is the effect of external field, as the system is identical in all other aspects. Thus the existence of grain-field type interactions is evident in the system but there were no agglomeration or flocculation as there were no sudden

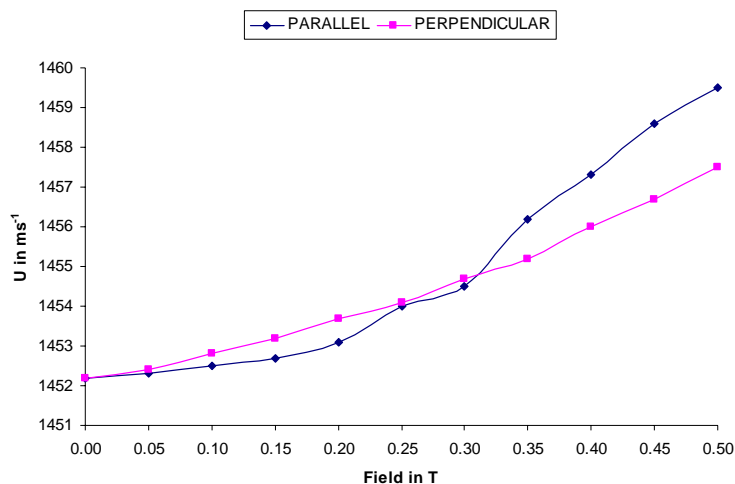

Figure 3: Variation of U with field strength.

changes in the trend of the sound velocity. The visual observation of the sample also reveals no precipitation/sedimentation.

The increase of sound velocity of a medium may be attribute to two chances as (i) an elevation in the pressure of the medium and (ii) the increase in compactness of the medium or the reduction in free space between the components. In the present case, pressure and frequency are fixed, so it is only the compactness that enhances the sound velocity.

Compactness in turn, may be due to the increase in the number of component molecules or the development of size of the components. The same fluid is used throughout the experiment and hence no chance for the change in the number of components is possible.

On the other hand, the application of external field may collect all the magnetic particles in the medium and make the component size to develop. However, the surfactant coated over the particles will restrict the agglomeration and hence the size. If the size of the component develops, more energy will be needed to overcome the inertial effects<sup>17</sup> and here, it is provided in the form of magnetic energy. Thus the effect of external magnetic field increases the size of the components in the medium and at the same time drastically reorient the particles in the system. Hence, the sound velocity increases whereas the density remains the same. However, the fluid is found to remain as magnetic fluid. It is

due to the surfactant, which protects the nano particles from excess carrier. In doing so, it creates strong interaction between the carrier particles.

The calculated values of  $\beta$  and  $L_f$  decrease with the increase strength of field whereas the  $Z$  increases. The ease with which a medium be compressed is indicated by the compressibility values.<sup>18</sup> The  $L_f$  is found to be a predominant factor in determining the nature of the sound velocity variations in the liquid mixtures.<sup>19</sup> The smaller values of  $\beta$  with increasing field (Fig. 4) revealed that the coated particles are forming a cage-like structure and thus a decrease in distance of separation exits. As the observed  $L_f$  decreases, it confirms the closeness of the particles that forms another support for the above observation (Fig. 5).

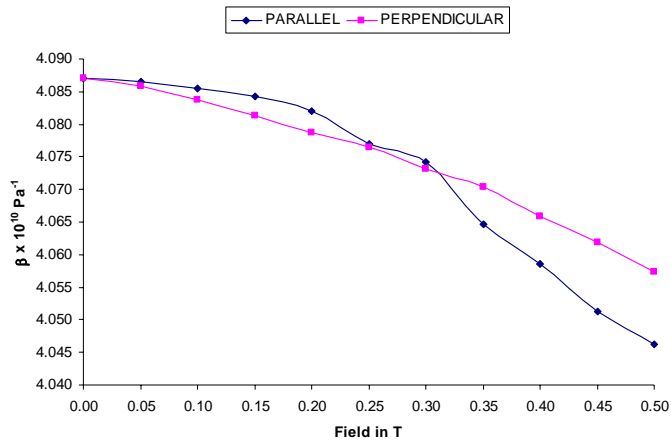

Figure 4: Variation of  $\beta$  with field strength.

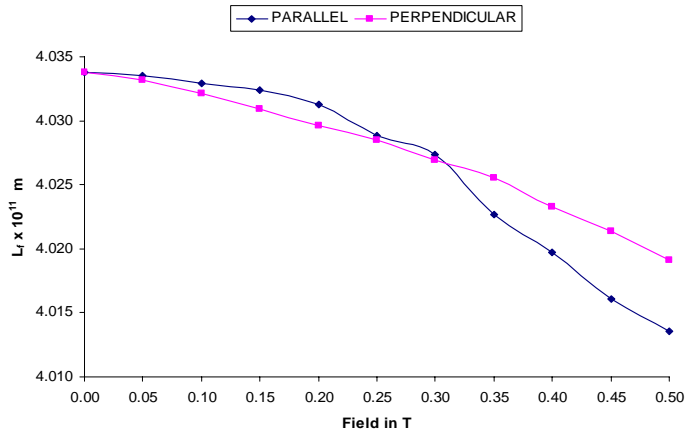

Figure 5: Variation of  $L_f$  with field strength.



The extent of opposition offered to the sound propagation is indicated by  $Z$  values. The external field is not only to develop the size of the components in the medium but at the same time it replaces the surrounding atmosphere by the heavy coated particles, thereby eliminating the light water particles, and hence increases the inertial effects, acoustic propagation is made less easier or the repulsion to sound is enhanced. Thus the  $Z$  values show an increasing trend just similar to the sound velocity with the increase in field.

The appreciable variation in the values of  $Z$  with respect to the external field suggests that the grain-field interaction is strong.<sup>20</sup> However, the grain-grain interaction is almost the same as the number of grain remains constant and also the grains are protected by the surfactant.

Table 2 lists the measured density and sound velocity together with the calculated parameters for the best ferrofluid sample kept under perpendicular magnetic field at 303 K. In this case also, a non-linear increase in the sound velocity is observed with increasing field strength, but not as appreciable as in parallel field (Fig. 3). However the observed values are higher than those under no field condition.

The increase of the sound velocity suggests the existence of interactions of the applied magnetic field in the taken system. It is to be remembered that the perpendicular component of the effective magnetic field is zero<sup>21</sup> and hence the magnetic field has no effect on the system in this case. As all the particles are ferromagnetic, having their own domain magnetism, some changes in the velocity due to the reorientation of the grains or reordering of the system are observed. Thus the observed sound velocity variations are less appreciable. In the case of parallel field, the observed variations are due to the formation of structure whereas in the case of perpendicular field, the observed variations are due to the reordering of the existing structure. Hence, in this case, grain-field type interaction is weak and grain-grain interaction is highly specific.

It is to be noted that the externally applied magnetic field causes an ordering of the magnetic moments of the particles, giving rise to a magnetization of the sample as a whole on a microscopic scale. This leads to the observed increase in sound velocity. However, if the external magnetic field is weak, thermal motion counteracts the orientation of the magnetic moments into the direction of the field. In a strong field, most of the particles become oriented and the magnetization of the sample attain saturated.<sup>22</sup> Thus, at lower fields, due to thermal motion, the changes in observed sound velocity may be smaller but at higher fields, such as at 0.50 T, a well-pronounced increase in sound velocity was observed. Further, the continuous increase of sound velocity indicates that the sample is not yet saturated.

Table 2: Measured and calculated parameters for the best sample kept under perpendicular field at 303 K.

Field T	$\rho$ $\text{kg m}^{-3}$	U $\text{ms}^{-1}$	$\beta \times 10^{10}$ $\text{Pa}^{-1}$	$L_f \times 10^{11}$ m	$Z \times 10^{-6}$ $\text{kg m}^{-2}\text{s}^{-1}$
0.00	1160.2	1452.2	4.0871	4.0338	1.6848
0.05	1160.2	1452.4	4.0859	4.0332	1.6851
0.10	1160.2	1452.8	4.0837	4.0321	1.6855
0.15	1160.2	1453.2	4.0814	4.0309	1.6860
0.20	1160.2	1453.7	4.0787	4.0296	1.6866
0.25	1160.2	1454.1	4.0764	4.0285	1.6870
0.30	1160.2	1454.7	4.0731	4.0269	1.6877
0.35	1160.2	1455.2	4.0703	4.0255	1.6883
0.40	1160.2	1456.0	4.0658	4.0233	1.6893
0.45	1160.2	1456.7	4.0619	4.0214	1.6900
0.50	1160.2	1457.5	4.0574	4.0191	1.6909

Skumiel et al.<sup>23</sup> concluded that at equilibrium, the magnitude of the magnetization is a function of the strength of external magnetic field, the volume concentration of the magnetic particles (their magnetic moments) and the temperature. In the present case, the latter two parameters are fixed and the only variable is the external magnetic field. Thus the present observations agree with the report of Skumiel et al.<sup>23</sup> that the magnitude of magnetization is found to vary with external field strength however non-linearly.

The state of magnetization is satisfactorily described by the classical Langevin law<sup>24</sup> for the magnetization of molecules of a paramagnetic gas. The respective expression, in the case of magnetic fluids, is fulfilled on the assumption of the absence of magnetic or electric dipole interaction between neighboring particles. Otherwise, the magnetic particles coagulate and the magnetic fluid loses its fluidity. Thus the observed increase in the velocity is not due to the dipole interactions of the magnetite particles but solely due to the grain-field interaction.

The application of external field has a definite interaction with the magnetic particles in the system and it leads to restructurization of the medium.<sup>25</sup> Spherical clusters arise, with a radius ranging from several tens of nanometers up to micrometers as well as chain-like clusters are accessible to microscopic observation.

The process of restructurization of the magnetic fluid requires some time, depending on the evolution of the aggregates with increasing strength of the external magnetic field.<sup>26, 27</sup> Under the effect of an external magnetic field, the particles of the ferrofluid aggregate and chain-clusters appear to arrange along the direction of the field.

The perusal of Table 2 further reveals that the observed variations in the calculated parameters of  $\beta$ ,  $L_f$  and  $Z$  lend a support to the idea that even though the particles are in cage-like formation that increases the grain-grain interaction, the existing grain-field type interactions are also not negligible.

#### 4. CONCLUSIONS

The parallel field is found to be more effective than the perpendicular field. The existence of grain-field interactions and grain-grain interactions are confirmed in the ferrofluid system and this make one to think of using the fluid for biomedical applications. Grain-field interactions are more favored in the parallel field whereas grain-grain interactions is in perpendicular field. Enhancement of chain structure formation is observed irrespective of the field orientation and it mainly depends on the field strength.

#### 5. REFERENCES

1. Parsons, J.D. (1975). Sound velocity in a magnetic fluid. *J. Phys. D: Appl. Phys.*, 8(10), 1219–1226.
2. Perry, M.P. & Jones, J.B. (1976). Hydrostatic loading of magnetic liquid seals, *IEEE Trans. Magn.*, 12(6), 798–800.
3. Nakamura, T. (1971). Magneto medicine: Biological aspects of ferromagnetic fine particles. *J. Appl. Phy.*, 42, 1320–1324.
4. Mehta, R.V. & Patel, J.M. (1987). Velocity anisotropy of ultrasound in magnetic fluids. *J. Magn. Magn. Mater.*, 65, 204–206.
5. Shrivastava, R., Vaidya, S.P., Patel, J.M. & Mehta, R.V. (1988). Ultrasonic velocity anisotropy of magnetic fluids. *Journal of Colloid and Interface Science*, 124, 248–251.

6. Chung, D.Y., Hung, H.Z. & Lin, J.X. (1983). Ultrasonic properties of magnetic fluids. *J. Magn. Magn. Mater.*, 39, 111–112.
7. Chung, D.Y. Hung, H.Z & Lin, J.X. (1987). Magnetic effects on the ultrasonic velocity and attenuation in magnetic fluids. *J. Magn. Magn. Mater.*, 65, 231–234.
8. Vaidya, S.P. & Mehta, R.V. (1983). Temperature dependence of the ultrasonic velocity on magnetic fluid subjected to an external field. *J. Magn. Magn. Mater.*, 39, 82–84.
9. Chung, D.Y. & Isler, W.E (1978). Ultrasonic velocity anisotropy in ferrofluids under the influence of a magnetic field. *J. Appl. Phys.*, 49(3), 1809–1814.
10. Jozefczak, A. (2003). The time dependence of the changes of ultrasonic wave velocity in ferrofluid under parallel magnetic field. *J. Magn. Magn. Mater.*, 256, 267–270.
11. Massart, R. (1981). Preparation of aqueous magnetic liquid in alkaline and acidic media. *IEEE Trans. Magn.*, 17(2), 1247–1248.
12. Kim, D.K., Zhang, Y., Kehri, J., Klason, T., Bjelke, B. & Muhammed, M. (2001). Characterization and MRI study of surfactant-coated superparamagnetic nanoparticles administered into the rat brain. *J. Magn. Magn. Mater.*, 225, 256–261.
13. Palaniappan, L. & Karthikeyan, V. (2005). Ultrasonic analysis in the ternary mixtures of 1,4 dioxane + carbontetrachloride + 1-butanol. *Indian J. Physics*, 79(2), 153–156.
14. Reddy, K.C., Subrahmanyam, S.V. & Bhimsenachar, J. (1964). Thermodynamics of binary liquid mixtures containing cyclohexane Part-1. *J. Phys. Soc. of Jpn.*, 19, 559–566.
15. Kannappan, V. & Vinayagam, S.C. (2007). Ultrasonic investigation of ion-solvent interactions in aqueous and non-aqueous solutions of transfer and inner transfer of metal ions. *Indian J. Pure Appl. Phys.*, 45(2), 143–150.
16. Kannappan, V. & Gandhi, I.N. (2007). Ultrasonic studies on charge transfer complexes of certain aldehyde with benzylamine and cyclohexylamine as donors in 1-hexane at 303 K. *Indian J. Pure Appl. Phys.*, 45(3), 221–225.
17. Palaniappan, L. & Nithyanandham, S. (2006). Molecular interaction studies of fructose in aqueous amylase solution. *Acta Ciencia Indica*, 37(3), 387–392.
18. Hykes, D., Hedrick, W.R. & Strachman, D.E. (1985). *Ultrasound physics and instrumentation*. New York: Churchill Livingstone, 25–40.
19. Kaulgud, M.V. (1963). Free length variations in liquid mixtures. *Z. Phys. Chem.*, 36, 365–368.
20. Palaniappan, L. (2002). Thermoacoustical studies of some iso-alcohols in cyclohexane with toluene. *Indian J. Pure Appl. Phys.*, 40, 828–830.

21. Lal, B. & Subrahmanyam, V. (1986). *A text book on electricity and magnetism*. New Delhi: Khanna Publishers, 256–258.
22. Henjes, K. (1994). Sound propagation in magnetic fluids. *Phys. Rev. E*, 50, 1184–1188.
23. Skumiel, A., Hornowski, T. & Labowski, M. (1998). Resonance absorption of the ultrasonic waves in magnetic liquids in DC magnetic field. *Ultrasonics*, 36, 421–426.
24. Kamienski, B. (ed). (1963). *Physical Chemistry*. Warsaw: PWN, 127–149.
25. Rosenweig, R.E. (1985). *Ferrohydrodynamics*. London: Cambridge University Press, 76–79.
26. Jones, G.A. & Belfield, D.G. (1990). Field induced agglomeration in thin films of magnetic fluids. *J. Magn. Magn. Mater*, 85, 37–39.
27. Hong, C.Y., Jang, I.J., Horng, H.E., Hsu, C.J., Yao, Y.D. & Yang, H.C. (1997). Ordered structures in Fe<sub>3</sub>O<sub>4</sub> kerosene based ferrofluids, *J. Appl. Phys.*, 81, 4275–4277.